

## INTRA / PRIMA

Flap-type / sight flow indicator



---

## **IMPRINT**

All rights reserved. Reproduction of this documentation in any form, whether in whole or in part, is prohibited without the prior written approval of MECON GmbH.

We reserve the right to make changes without prior notice.

Copyright 2018 by MECON GmbH - Röntgenstraße 105 - 50169 Kerpen - Germany

---

## Contents

<b>1</b>	<b>SAFETY INSTRUCTIONS.....</b>	<b>4</b>
1.1	Appropriate usage.....	4
1.2	Manufacturer's safety instructions.....	4
<b>2</b>	<b>DEVICE SCOPE .....</b>	<b>5</b>
2.1	Scope of delivery .....	5
2.2	Type plates.....	6
<b>3</b>	<b>INSTALLATION AND METHOD OF OPERATION .....</b>	<b>7</b>
3.1	Installation notes.....	7
3.2	Installation .....	8
3.3	Operating Method.....	10
<b>4</b>	<b>COMMISSIONING .....</b>	<b>11</b>
4.1	Limit contact .....	11
<b>5</b>	<b>TECHNICAL DATA.....</b>	<b>14</b>
5.1	INTRA (for measuring transparent liquids).....	14
5.2	Physical design (INTRA) .....	14
5.3	PRIMA (for measuring opaque/cloudy liquids).....	15
5.4	Physical design (PRIMA).....	15
5.5	Dimensions and weights.....	16
5.6	Measuring range (based on measurement of H <sub>2</sub> O) .....	17
5.7	Contact device .....	18
5.8	Round connector .....	20
<b>6</b>	<b>DESIGNATION KEY .....</b>	<b>21</b>
6.1	INTRA (for measuring transparent liquids).....	21
6.2	PRIMA (for measuring opaque/cloudy liquids).....	23
<b>7</b>	<b>SERVICE.....</b>	<b>25</b>
7.1	Storage .....	25
7.2	Maintenance .....	25
7.3	Returning the device to the manufacturer .....	25
7.4	Disposal .....	26

# 1 SAFETY INSTRUCTIONS

## 1.1 Appropriate usage

The INTRA / PRIMA flap flow indicators are used for monitoring and indicating the flow of liquids in closed pipelines. The PRIMA device can also be optionally equipped with an inductive contact for remote transmission of a switching point.

The sturdy, operationally reliable design allows the devices to be used in all applications requiring reliable momentary indication and flow rate monitoring. The main areas of application for the flap-type flow indicator are plant construction, machine construction, building services equipment, in the water industry and the wastewater industry.

### *Warning!*



*The operator alone carries the sole responsibility for determining the suitability of the measuring devices for the intended area of application, especially regarding the corrosion resistance of the material used against the substance being measured. In particular, it must be ensured that the selected materials in the components of the measuring device that come into contact with the media are suitable for use with the process media used.*

*The manufacturer accepts no liability of any kind for damages resulting from misuse, incorrect use or usage outside the specified intended uses.*

*The device may only be used within the pressure and temperature limits specified in the operating manual.*

## 1.2 Manufacturer's safety instructions

The manufacturer is not liable for damage of any kind resulting from the use of the device, including but not restricted to direct, indirect or incidental damage and consequential damage.

The warranty specified in the relevant product documentation and in our General Terms and Conditions of Business applies to all products purchased from the manufacturer.

The manufacturer reserves the right to modify the content of the documents, including the liability waivers, without prior notice and accepts no liability of any kind for any possible consequences of such changes.

The responsibility for ensuring the suitability of the flow meter for each respective application lies exclusively with the operator. MECON GmbH accepts no liability of any kind for

the consequences of incorrect use, modifications and repairs performed by the customer.

In the case of return shipment, the parts subject to complaint must be cleaned of all hazardous substances before being returned to us (see 7.3).

This operating manual describes the correct installation, operation and maintenance of the device.

To prevent injury to the user and damage to the device, it is essential to carefully read this operating manual and adhere to the instructions and specifications contained therein before bringing the device into operation.

This documentation does not cover special versions and models adapted for special applications.

## 2 DEVICE SCOPE

### 2.1 Scope of delivery



Fig. 1: Scope of delivery

- ① INTRA / PRIMA flap-type flow indicator
- ② Operating manual

## 2.2 Type plates

### INTRA / PRIMA Type plate

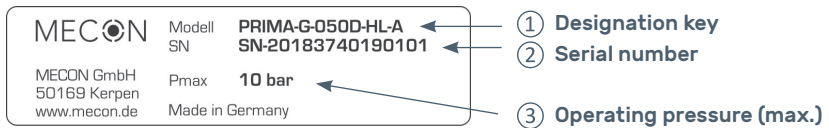
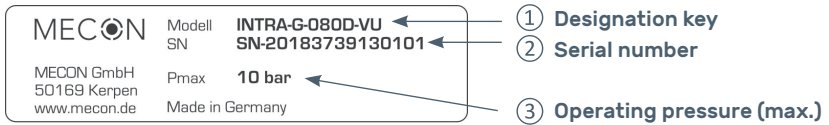

Fig. 2 INTRA / PRIMA flap-type flow indicator type plate

## 3 INSTALLATION AND METHOD OF OPERATION

### 3.1 Installation notes



#### ***Information!***

***All devices have been carefully checked for correct functionality before shipping.***

***Check the packaging for signs of damage or incorrect handling immediately on receipt of the goods.***

***Notify the freight forwarding company and your sales contact responsible of any damage discovered. In this case, a description of the damage, device type, delivery note number and serial number of the device must be provided.***

***Unpack the device carefully to prevent damage.***

***Check the completeness of the delivery against the delivery note. Check the type plate to ensure that the delivered flap-type flow indicator corresponds to the device that you have ordered.***

### 3.2 Installation

#### Installation

The flap-type flow indicator can be installed horizontally or vertically, as required. When installing horizontally with a left/right or right/left flow direction, take care to ensure that the device is installed with the scale facing forwards (visible area). This is essential for ensuring correct functionality of the device.

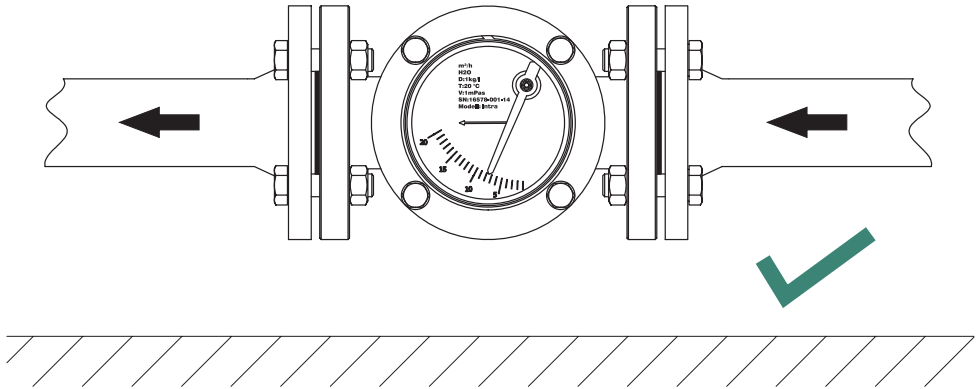

Fig. 3 Installation orientation (horizontal) - correct

The installation orientation in Fig. 4 is incorrect because the scale faces upwards. This is essential for ensuring correct functionality of the device. (Also applies to a scale oriented downwards.)

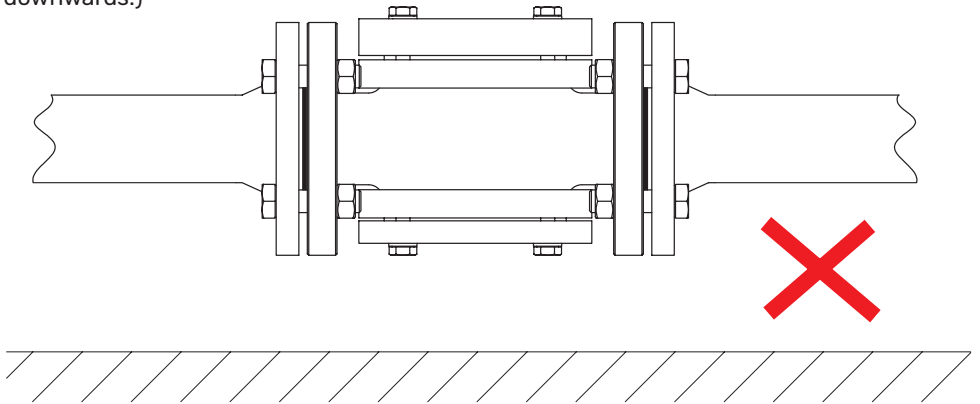

Fig. 4 Installation orientation (horizontal) - incorrect



## Installation

- » Ensure that the actual operating conditions (pressure and temperature) do not exceed the limits specified on the type plate.
- » On installation, the connecting flanges of the flap-type flow indicator are to be fitted with appropriate flat gaskets, which are not included in the scope of delivery.
- » Before installation, the transport lock inside the device is to be removed and the device checked to ensure freedom of movement of the flap.
- » The pipe ends are to be fitted with suitably matching connecting flanges.
- » The device must be installed free of tension in the pipeline, which means that the pipes must be centrally positioned and aligned.
- » On installation, please note the flow direction indicated by the arrow on the scale (scale label can be read horizontally).

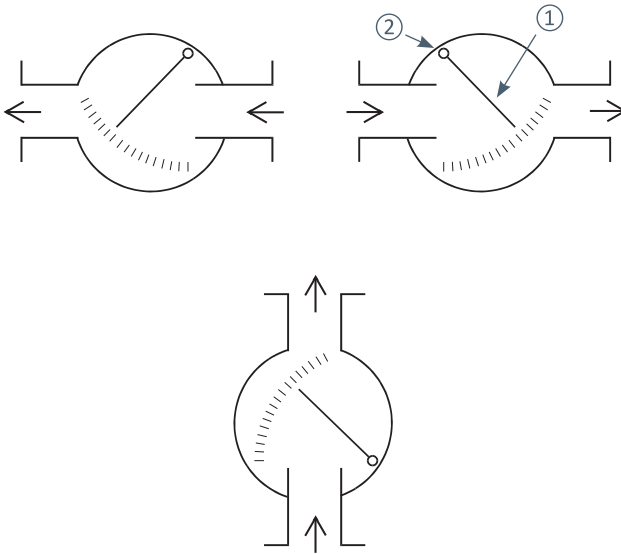

Fig. 5: Flow direction

### 3.3 Operating Method

The flap-type flow indicators operate using the flap principle. The operating principle of the two flap-type flow indicators is shown schematically in Fig. 5. The measurement flap (1) in the fitting rotates around an axis (2). In the idle condition (i.e. no flow), the flap seals the pipeline due to its own weight. As soon as liquid flows, the flap raises according to the flow rate. The respective flow rate can be read directly from the position of the flap in clear liquids (INTRA).

In cloudy and opaque liquids, a magnet attached to the flap transmits the motion of the flap to an externally mounted pointer that shows the flow on a scale (PRIMA). The scale and indicator are protected against external influences and soiling by a plastic pane.

As standard, the scale is in  $\text{m}^3/\text{h}$  and is calculated based on the measurement substance, pressure and temperature operating data specified by the customer if the density deviates from  $1 \text{ kg/l}$  ( $62.43 \text{ lb/cu.ft}$ ).

An inductive contact (optionally available for the PRIMA device) can be activated via a contact vane mounted on the pointer.

## 4 COMMISSIONING

Correct installation of the device is a basic prerequisite for commissioning. When commissioning new plants, material residues are sometimes transported in the media being measured, which can possibly become caught on the transmission magnet (measuring flap). In this case, the device must be cleaned.

To prevent pressure surges caused by gas bubbles, the plant should be started against a closed valve that is then adjusted to the normal operating flow rate. The valve can be installed upstream or downstream of the indicator.

If the magnetic coupling between the flap in the flap-type flow indicator and the pointer is interrupted, the pointer can be lifted back into position using an auxiliary magnet. Alternatively, the flap must be opened fully once and then closed again. The magnetic coupling will then function correctly after this.

### Reading measurements

The measurements value is read directly at the flap on INTRA flap-type flow indicators. The flow rate is read via the upper edge against a scale applied to the front pane. The lower edge of the flap is the reading edge.

The measurement is read directly via the pointer on the scale on PRIMA flap-type flow indicators.

The measured value read on the scale is only correct within the specified measuring accuracy when the operating conditions at the measuring point (media, operating pressure and temperature) correspond to the operating condition data on the scale.

### 4.1 Limit contact

In addition to the local indicator, the PRIMA flap-type flow indicator provides a remote monitoring function with limit value contacts and pre-configured switching point. The contact exhibits bistable behaviour.

Uncontrollable current and voltage spikes can occur with inductive or capacitive loads, e.g. circuit breakers or solenoid valves. Such spikes can also occur in cables above a certain length, depending on the cable cross-sections. To prevent this, we recommend the use of an additional I&C contact protection relay. This increases the switching rating and prevents inductive and capacitive spikes from occurring. The electrical connection data and limit values specified in section 5.3 are to be adhered to.

#### Connecting the limit value contact

Electrical connection of the device is to be performed according to the relevant VDE regulations and the regulations of the local electricity supply company.

- » Disconnect the plant from the power supply before connecting the contact.
- » Provide a protection circuit for the relay according to the power consumption of your application.
- » Install fuse elements appropriate to the downstream power consumption.
- » The cables are connected using the angle connectors provided. The circuit diagram of the limit value contact is shown in section 5.3.

### Adjusting the limit value contact

The PRIMA flap-type flow indicator is already adjusted to the switching point required by the customer, if this has been specified. If a new setting is necessary, the switching point of the contact can be adjusted via the pointer vane.

The switching function can be reversed, depending on whether the pointer vane enters or leaves the contact at the desired switching point.

The protective pane must be removed as follows in order to adjust the switching point:

1. Remove the clamping ring from the groove above the protective pane using a narrow screwdriver.
2. Remove the protective pane from the ring.
3. Take care not to lose the O-ring under the pane! It protects the scale chamber from dust and dirt.

The contact and indicator vane are now accessible for further adjustment.

#### **WARNING**

*Every device is checked for leaks before delivery. Loosening the hexagonal bolts in the housing ring will lead to leaks. Escaping media can possibly cause material damage or present a health hazard. MECON GmbH accept no liability of any kind for incorrect use.*



Ensure that the measured material line is shut off before starting the adjustment procedure.

**Adjusting the contact:**

1. Move the pointer manually to the desired switching point and fasten in place. Ensure that the pointer cannot move during the adjustment procedure.
2. Release the indicator vane via the pointer axle nut.
3. Coarse adjustment of the switching point is performed via the pointer vane. Do this by rotating the vane until one of the edges reaches the switch contact, according to the contact switching mode and the flow direction.

The switching behaviour of the contact can be configured depending on whether the pointer vane enters the contact or leaves the contact at the switching point to be adjusted.

4. Fasten the pointer vane in place by re-tightening the pointer axle nut. (The pointer must not move when doing this!)
5. Release the pointer from the retaining fixture and check that it can move freely over the entire measuring range.
6. Check the switching point by manually moving the pointer across the switching point.

Fine adjustment is made by moving the contact.

1. Loosen the grub screw at the contact.
2. Carefully move the contact along the housing wall by a maximum of 2 mm.
3. Re-tighten the grub screw and check the switching point by manually moving the pointer across the switching point.

The Plexiglas pane must be fitted again after successfully adjusting the contact.

1. Insert the O-ring into the corresponding groove.
2. Fit the Plexiglas protective pane. Take care to ensure that the O-ring does not slip out of the groove.
3. Fit the clamping ring carefully into the corresponding groove.

## 5 TECHNICAL DATA

### 5.1 INTRA (for measuring transparent liquids)

<b>Measuring principle</b>	Flap-type flow indicator with visual indicator
<b>Flow direction</b>	From the bottom to the top or left to right or right to left
<b>Installation orientation</b>	Horizontal or vertical
<b>Measurement deviation</b>	±5.0 % of full-scale deflection
<b>Operating conditions</b> Max. ambient temperature Max. operating temperature Max. operating pressure	+ 90 °C + 100 °C 10 bar
<b>Protection degree</b>	Based on IP 54
<b>Options</b>	Silicon-free version
<b>Permits and approvals</b>	Classification according to the pressure vessel directive 2014/68 EC 4.3

### 5.2 Physical design (INTRA)

Housing	Pressure rings	Measuring flap and bearing	Inspection window	Blank flange/ring	Seal	Nominal size
Grey-cast iron	Steel (Mat. # 1.0570)	Stainless steel (Mat. #1.4571)	Soda lime glass	Soda lime glass	FKM	DN 15 - DN 150 EN1092-1, ½" to 6" ANSI B16.5
Stainless steel (Mat. # 1.4571)	Stainless steel (Mat. # 1.4571)	Stainless steel (Mat. # 1.4571)	Borosilicate glass	Borosilicate glass	FKM	DN 25 - DN 150 EN1092-1, 1" to 6" ANSI B16.5

We can offer other materials such as seals and rubber components on request.

### 5.3 PRIMA (for measuring opaque/cloudy liquids)

<b>Measuring principle</b>	Flap-type flow indicator with pointer mechanism
<b>Flow direction</b>	From the bottom to the top or left to right or right to left
<b>Installation orientation</b>	Horizontal or vertical
<b>Measurement deviation</b>	±5.0% of full-scale deflection
<b>Operating conditions</b> Max. ambient temperature Max. operating temperature Max. operating pressure	+ 90 °C + 100 °C 10 bar
<b>Contact device</b>	None 1 x inductive contact - SB3,5-E2 (3-wire) 1 x NAMUR inductive contact - SC3,5-N0-BU (2-wire)
<b>Protection degree</b>	Based on IP 54, switching contact IP 53
	Polycarbonat
<b>Options</b>	Silicon-free version
<b>Permits and approvals</b>	Classification according to the pressure vessel directive 2014/68 EC 4.3

### 5.4 Physical design (PRIMA)

Housing	Pressure rings	Measuring flap and bearing	Pane	Blank flange/ ring	Seal	Nominal size
Grey-cast iron	Steel (Mat. # 1.0570)	Stainless steel (Mat. # 1.4571)	Stainless steel (Mat. # 1.4571)	Steel (Mat. # 1.0570)	FKM	DN 15 - DN 150 EN1092-1, ½" to 6" ANSI B16.5
Stainless steel (Mat. # 1.4571)	Stainless steel (Mat. # 1.4571)	Stainless steel (Mat. # 1.4571)	Stainless steel (Mat. # 1.4571)	Stainless steel (Mat. # 1.4571)	FKM	DN 25 - DN 150 EN1092-1, 1" to 6" ANSI B16.5

We can offer other materials such as seals and rubber components on request.

## 5.5 Dimensions and weights

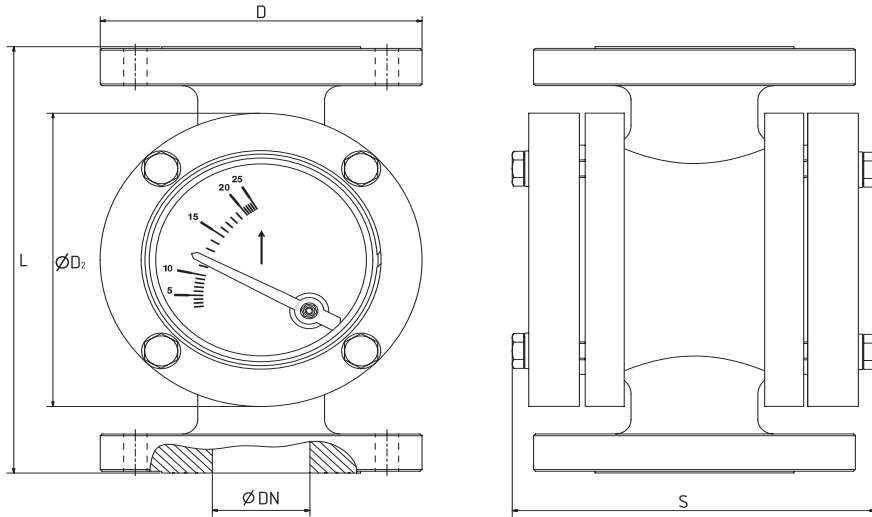

Fig. 6 Dimensions of the PRIMA flap-type flow indicator (identical to the INTRA dimensions)

DN	ANSI	Ø D (mm)	L +0/-3 (mm)	Ø D <sub>2</sub> approx. (mm)	S approx. (mm)	Weight (kg)
15	-	95	170	119	145	8.0
20	-	105	170	119	145	8.5
25	1"	115	170	119	145	9.0
32	-	140	240	165	176	16
40	1½"	150	240	165	176	16
50	2"	165	240	165	176	17
65	2½"	185	280	185	201	22
80	3"	200	320	225	214	34
100	4"	220	350	245	267	43
125	5"	250	380	285	299	58
150	6"	285	380	295	299	64

Tab. 1 Dimensions and weights



## 5.6 Measuring range (based on measurement of H<sub>2</sub>O)

DN	Measuring range Horizontal flow (m <sup>3</sup> /h)	Measuring range Vertical flow (m <sup>3</sup> /h)	Max. operating pres- sure for INTRA (visual indicator) (bar)	Max. operating pressure for PRIMA (pointer mechanism) (bar)
15	0.2 – 1.0 0.3 – 6.0	0.2 – 1.5 1.0 – 6.5	10	10
20	0.2 – 1.0 0.3 – 6.0	0.2 – 1.5 1.0 – 6.5	10	10
25	0.2 – 1.0 0.3 – 6.0	0.2 – 1.5 1.0 – 6.5	10	10
32	0.5 – 4.0 3.0 – 30	0.5 – 4.0 2.5 – 25	9.0	10
40	0.5 – 4.0 3.0 – 30	0.5 – 4.0 2.5 – 25	9.0	10
50	0.5 – 4.0 3.0 – 30	0.5 – 4.0 2.5 – 25	9.0	10
65	1.0 – 8.0 2.5 – 50	2.0 – 15 5.0 – 40	10	10
80	1.0 – 10 7.0 – 70	2.0 – 10 5.0 – 50	10	10
100	1.5 – 15 12 – 120	1.5 – 15 10 – 100	10	10
125	2.0 – 20 14 – 140	2.0 – 20 12 – 120	7.0	10
150	2.0 – 25 16 – 160 15 – 200*	4.0 – 25 15 – 140	6.5	10

Tab. 2 Measuring ranges, \*only with glass pane (The table indicates the minimal and maximal measuring range. All ranges between are on request.)

The minimum and maximum measuring ranges respectively are specified. All intermediate measuring ranges on request. The average value is 20–30 mbar depending on the flow rate.

## 5.7 Contact device

The PRIMA flap-type flow indicator can be optionally equipped with the following two contact devices:

<b>Inductive contact (SB 3,5-E2) 3-wire system (non EX)</b>	
<b>Properties</b>	Adjustable, bistable
<b>Switching function</b>	Normally-closed, normally-open
<b>Switched voltage (max.)</b>	10 to 30 V DC
<b>Power consumption:</b> Pointer vane not acquired Pointer vane acquired	$V \leq 0.3 \text{ V} / I_0 \leq 15 \text{ mA}$ Switched voltage $\leq 3 \text{ V}$
<b>Continuous current</b>	max. 100 mA
<b>Temperature resistance</b>	- 25 to + 70 °C
<b>EMC according to</b>	EN 80947-5-2
<b>Protection degree</b>	IP 67
<b>Connection diagram</b>	
<b>Angle connector</b>	
1	BU
2	BN
3	BK
PE	Not connected

<b>NAMUR inductive contact (SC 3,5-N0-BU) 2-wire system (NAMUR)</b>	
<b>Properties</b>	Adjustable, bistable
<b>Switching function</b>	Normally-closed, normally-open
<b>Switched voltage</b>	max. 8 V DC
<b>Current consumption:</b> Pointer vane not acquired Pointer vane acquired	$\geq 3$ mA $\leq 1$ mA
<b>Temperature resistance</b>	- 25 to + 100 °C
<b>EMC according to</b>	NE21
<b>SIL according to</b>	IEC 61508
<b>Protection degree</b>	IP 67
<b>Connection diagram</b>	
<b>Angle connector</b> 1 2 3 PE	BU BN Not connected Not connected

The device is connected using an angle connector (3 pins + PE) according to DIN 46350 Design A with an M 16 cable gland (IP 65)

## 5.8 Right-angle plug

Angular coupling, type A	
Description	Female connector with central screw M 3 x 35
Type	GDM 3016 black
No. of poles	3 + PE
Cable gland	M 16
Wire cross-section	max. 1.5 mm <sup>2</sup>
Standard	DIN EN 175 301-803-A
Housing color	black
Design	A
Pin dimension	6.3 mm x 0.8 mm / 4.8 mm x 0.8 mm
Rated voltage	AC / DC 250 V
Rated current	16 A
Contact resistance	≤4 mΩ
Connection type	screwing
Degree of protection	(IEC 60529) IP 65
Temperature range	-40 °C to +125 °C
Contact surface material	Sn
Contact carrier material	PA
Housing material	PA
Gasket	profile seal NBR
Dimensions	

## 6 DESIGNATION KEY

### 6.1 INTRA (for measuring transparent liquids)

The designation key is composed as follows:



#### Physical design

##### ① Housing

	Housing	Pressure rings	Measuring flap and bearing	Inspection window	Blank flange/ring	Seal
<b>G</b>	Grey-cast iron	Steel (Mat. # 1.0570)	Stainless steel (W. no. 1.4571)	Soda lime glass	Steel (Mat. # 1.0570)	FKM
<b>E</b>	Stainless steel (Mat. # 1.4571)	Stainless steel (Mat. # 1.4571)	Stainless steel (Mat. # 1.4571)	Borosilicate glass	Stainless steel (Mat. # 1.4571)	FKM

##### ② Nominal size

	Connection	Grey-cast iron housing	Stainless steel iron housing
<b>015D</b>	DN 15 EN1092-1 PN 40	X	-
<b>020D</b>	DN 20 EN1092-1 PN 40	X	-
<b>025D</b>	DN 25 EN1092-1 PN 40	X	X
<b>032D</b>	DN 32 EN1092-1 PN 40	X	X
<b>040D</b>	DN 40 EN1092-1 PN 40	X	X
<b>050D</b>	DN 50 EN1092-1 PN 16	X	X
<b>065D</b>	DN 65 EN1092-1 PN 16	X	X
<b>080D</b>	DN 80 EN1092-1 PN 16	X	X
<b>100D</b>	DN 100 EN1092-1 PN 16	X	X
<b>125D</b>	DN 125 EN1092-1 PN 16	X	X
<b>150D</b>	DN 150 EN1092-1 PN 16	X	X

② **Nominal size**

	Connection	Grey-cast iron housing	Stainless steel iron housing
<b>025A</b>	1" ASME Class 150	X	X
<b>040A</b>	1½" ASME Class 150	X	X
<b>050A</b>	2" ASME Class 150	X	X
<b>065A</b>	2½" ASME Class 150	X	X
<b>080A</b>	3" ASME Class 150	X	X
<b>100A</b>	4" ASME Class 150	X	X
<b>125A</b>	5" ASME Class 150	X	X
<b>150A</b>	6" ASME Class 150	X	X

③ **Flow direction**

<b>VU</b>	From the bottom to the top (vertical line)
<b>HL</b>	From the left to the right (horizontal line)
<b>HR</b>	From the right to the left (horizontal line)

④ **Options**

<b>Y04</b>	Silicon-free version
------------	----------------------

Specification of the substance to be measured, the operating temperature, density, viscosity and measuring range is mandatory when placing the order.

## 6.2 PRIMA (for measuring opaque/cloudy liquids)

The designation key is composed as follows:

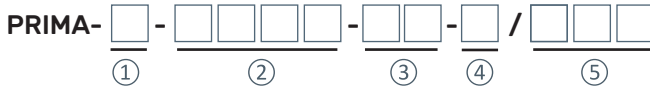

### Physical design

#### ① Housing

	Housing	Pressure rings	Measuring flap and bearing	Pane	Blank flange/ring	Seal
<b>G</b>	Grey-cast iron	Steel (Mat. # 1.0570)	Stainless steel (Mat. # 1.4571)	Stainless steel (Mat. # 1.4571)	Steel (Mat. # 1.0570)	FKM
<b>E</b>	Stainless steel (Mat. # 1.4571)	Stainless steel (Mat. # 1.4571)	Stainless steel (Mat. # 1.4571)	Stainless steel (Mat. # 1.4571)	Stainless steel (Mat. # 1.4571)	FKM

#### ② Nominal size

	Connection	Grey-cast iron housing	Stainless steel iron housing
<b>015D</b>	DN 15 EN1092-1 PN 40	X	-
<b>020D</b>	DN 20 EN1092-1 PN 40	X	-
<b>025D</b>	DN 25 EN1092-1 PN 40	X	X
<b>032D</b>	DN 32 EN1092-1 PN 40	X	X
<b>040D</b>	DN 40 EN1092-1 PN 40	X	X
<b>050D</b>	DN 50 EN1092-1 PN 16	X	X
<b>065D</b>	DN 65 EN1092-1 PN 16	X	X
<b>080D</b>	DN 80 EN1092-1 PN 16	X	X
<b>100D</b>	DN 100 EN1092-1 PN 16	X	X
<b>125D</b>	DN 125 EN1092-1 PN 16	X	X
<b>150D</b>	DN 150 EN1092-1 PN 16	X	X

② **Nominal size**

	Connection	Grey-cast iron housing	Stainless steel iron housing
<b>025A</b>	1" ASME Class 150	X	X
<b>040A</b>	1½" ASME Class 150	X	X
<b>050A</b>	2" ASME Class 150	X	X
<b>065A</b>	2½" ASME Class 150	X	X
<b>080A</b>	3" ASME Class 150	X	X
<b>100A</b>	4" ASME Class 150	X	X
<b>125A</b>	5" ASME Class 150	X	X
<b>150A</b>	6" ASME Class 150	X	X

③ **Flow direction**

<b>VU</b>	From the bottom to the top (vertical line)
<b>HL</b>	From the left to the right (horizontal line)
<b>HR</b>	From the right to the left (horizontal line)

④ **Contact device**

<b>A</b>	Without contact device
<b>B</b>	1 x inductive contact (SB 3,5-E2)
<b>J</b>	1 x NAMUR inductive contact (SC 3,5-N0-BU)

⑤ **Options**

<b>C15</b>	ATEX certificate
<b>Y03</b>	Special scaling (double scale)
<b>Y04</b>	Silicone-free version

Specification of the substance to be measured, the operating temperature, density, viscosity and measuring range is mandatory when placing the order.



---

## 7 SERVICE

### 7.1 Storage

Store the emptied device in a dry, dust-free location. Avoid direct sunlight and heat. The permissible storage temperature range is -20 to +60 °C. Avoid external loads on the device.

### 7.2 Maintenance

The flap-type flow indicator is opened from the rear. This is done by releasing the rear cover fastening screws and removing the rear cover. Remove any dirt that may be present in the housing and any deposits from the flap. The flap is mounted on a stainless steel shaft in a needle bearing. If this has too much play then open the device at the front. Then loosen the locking nuts and tighten the bearing screws. Then re-tighten the locking nuts. For this, the flap must be brought close enough to the front stainless steel disc so that it rubs lightly on this disc when the seal is not fitted. The flap can then move freely when the seal is fitted before final reassembly. The pointer must be able to move freely over the plate. Take care to ensure that you seal the device leak-tight again.

### 7.3 Returning the device to the manufacturer

Due to the careful production process and thorough final inspection of the device, fault-free usage can be expected on installation and during operation.

If the device must nevertheless be returned to MECON GmbH, then the following points must be observed:

#### **Warning!**



*Due to the legal regulations on environmental protection and work safety, and to protect the health and safety of our employees, all devices returned to MECON GmbH for repair must be free of poisonous and hazardous substances. This also applies to cavities within the device. If necessary, the device must be neutralised and/or rinsed clean by the customer before being returned to MECON GmbH.*

» <https://www.meccon.de/de/ruecksendungen/>

## 7.4 Disposal



***Warning!***

***The locally applicable regulations for disposal of the device in your country must be adhered to.***

---

## NOTES



**MECON GmbH**  
Röntgenstr. 105  
50169 Kerpen  
Germany

**Ph.:** +49 (0) 2237 600 06 - 0  
**Fax:** +49 (0) 2237 600 06 - 40  
**Email:** [info@mecon.de](mailto:info@mecon.de)

**Web:** [www.mecon.de](http://www.mecon.de)